

# MP2430-03

Φ24mm Graphite brush

## Main parameters

- Four-magnetic pole
- 11W
- 5100rpm
- 15.8mNm



## Technical illustration

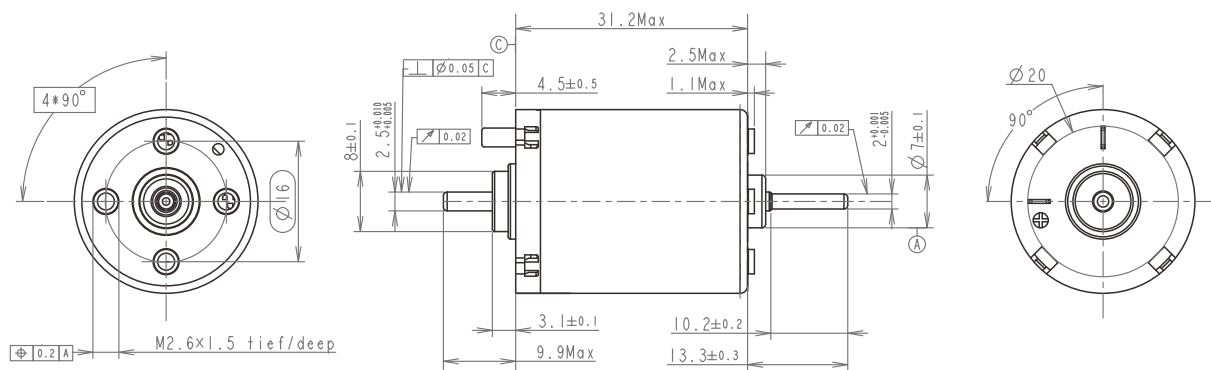

## Motor data (Rated value)

Rated voltage	V	12
Air -load speed	rpm	6200 ± 10%
No-load current	A	0.4 (Max)
Rated speed	rpm	5100 ± 10%
The rated torque	mNm	15.8
Rated current	A	1.2 ± 10%
Blocking torque	mNm	95 ± 7%
Blocking current	A	5.8 ± 10%
Maximum efficiency	%	65

## Motor constants (Rated value)

Phase terminal resistance	Ω	2 ± 10%
Phase terminal inductance	mH	NA ± 10%
Torque constant	mNm/A	18 ± 20%
Speed constant	rpm/V	515 ± 20%
Speed/torque gradient	rpm/mNm	65 ± 20%
Mechanical time constant	ms	NA ± 20%
Rotor inertia	gcm <sup>2</sup>	10 ± 20%

Note: Can be customized according to customer requirements